



SCHOOL
GAMES



Team Wigan



Year 5/6 High 5 Netball COMPETITIVE

Standish CHS 23rd May 2024
3.45pm - 5.30pm



Who?

This competition is for young people who take part in sport outside of school. Pupils should be well practiced and fully aware of the rules of the game.

On your marks

Why?

To support individual development in sport

Team Composition

5 on court at a time. Max squad size 9. Max 3 boys.

Get Set

Event Format

The event will follow a traditional format where teams all play each other to result in a winning team. Teams may be split into pools, followed by crossover semi-finals and a final depending on numbers. Pools will be drawn at random

Event Staff

The event will be supported by sports leaders from secondary schools.

Go



Rewards

Participation certificates will be available to all schools electronically. Medals will be presented to first, second and third placed teams.

Rules of the Game

Please Note: PLEASE BRING OWN BIBS.

Team Composition

Squads should consist of 7, 8 or 9 players with 5 on court at any one time.

The squad is made up with the following:

- C: Centre
- GS: Goal Shooter
- GK: Goal Keeper
- GA: Goal Attack
- GD: Goal Defence

When off court players can assume the following roles:

Scorers: Keep a simple score card for their own team.

Time keeper: Time the quarters and indicate to the umpire when the quarter is finished.

Centre pass marker: Keep note of whose centre pass it is and indicate to the umpire.

High 5 Netball is a game for both boys and girls. However, no team is allowed more than three boys. The following is therefore permitted:

- Squad of 7 - Max 3 boys
- Squad of 8 - Max 3 boys
- Squad of 9 - Max 3 boys

Only two boys are allowed on the court at the same time.

Court/Equipment Requirements

- High 5 netball is played on a normal full size netball court.
- Size 4 balls will be used.
- Posts should be lowered to 9ft/2.74m.

IN CASE OF VERY WET WEATHER THE EVENT WILL BE POSTPONED.

Points system will be as follows:

Win = 3 Points

Draw = 2 Points

Lose = 1 point

Duration of the Game

Dependant on the number of teams entered each match will have an allocation of one 7/8 minute period with 2 minutes between games to move court and for the squad to be rotated.

Playing the Game

The tournament will be played in accordance with the England Netball rules. The decision of the tournament referees will be final in all cases.

Start of Play:

- Team Captains toss a coin to determine who takes the first Centre Pass. Subsequent centre passes must be taken alternately.
- Play is started by a pass from the 'Centre', who stands with both feet in the centre circle.
- At the start of play the GS, GA, GD and GK may be anywhere in the goal third. The opposing Centre shall be in the centre third and free to move.
- When the umpire blows the whistle, the Centre must pass the ball within 4 seconds and obey the Footwork rule. The ball must be caught or touched in the centre third.

Playing the Ball:

A player must:

- Pass or shoot within 4 seconds.
- Obey the footwork rule.

A player may not:

- Deliberately kick the ball.
- Bounce the ball more than once.
- Hand or roll the ball to another player.
- Place their own hands on a ball held by an opponent.
- Throw the ball while sitting/lying on the ground.
- Use the goalpost as a support in receiving a ball going out of court or to gain balance.
- Throw the ball over a complete third without it being touched or caught by another player in that third.
- Regain possession of the ball, having dropped or thrown it, before it has been touched by another player.
- Penalty: Free Pass.

Footwork Rule:

- A player may receive the ball with one foot grounded or may jump to catch the ball and land on one foot. While that landing foot remains on the ground the other foot may be moved in any direction and any number of times, pivoting on the landing foot if desired. Hopping is not allowed.
- A player may receive the ball whilst both feet are grounded, or may jump to catch and land on both feet simultaneously. The player may then choose to move either foot and the remaining foot shall then be considered to be the landing foot. Proceed as in a) above.
- Penalty: Free Pass.

Scoring a Goal:

- A goal may only be scored by the Goal Shooter or the Goal Attack from within the shooting circle.

Obstruction:

- The player with the ball must be permitted an unimpeded throwing or shooting action. One jump to intercept a throw or shot at goal is permitted provided that the player is at least 1m away and that the arms are not outstretched prior to the jump. Jumping up and down in front of a player is not permitted.
- Penalty: Penalty Pass or Shot.

Contact:

- No player shall knock or push an opponent or interfere with his/her play, either accidentally or deliberately.
- Penalty: Penalty Pass or Shot.

Out of Court:

- A ball is out of court when it, or a player touching it, touches the ground or an object outside the court. The line counts as part of the court. If the ball hits the post and bounces back into court, it is still in play.

The Throw-in:

- The throw-in is taken at the point where the ball crossed the line. Any player allowed in that part of the court may take the throw-in and must stand outside the court with both feet behind the line. When the player taking the throw-in has checked that all other players are on court, she/he must release the ball within 4 seconds.

Offside:

- A player is offside if she/he enters any area of the court in which she/he is not allowed.
- Penalty: Free Pass.

Rotation patterns

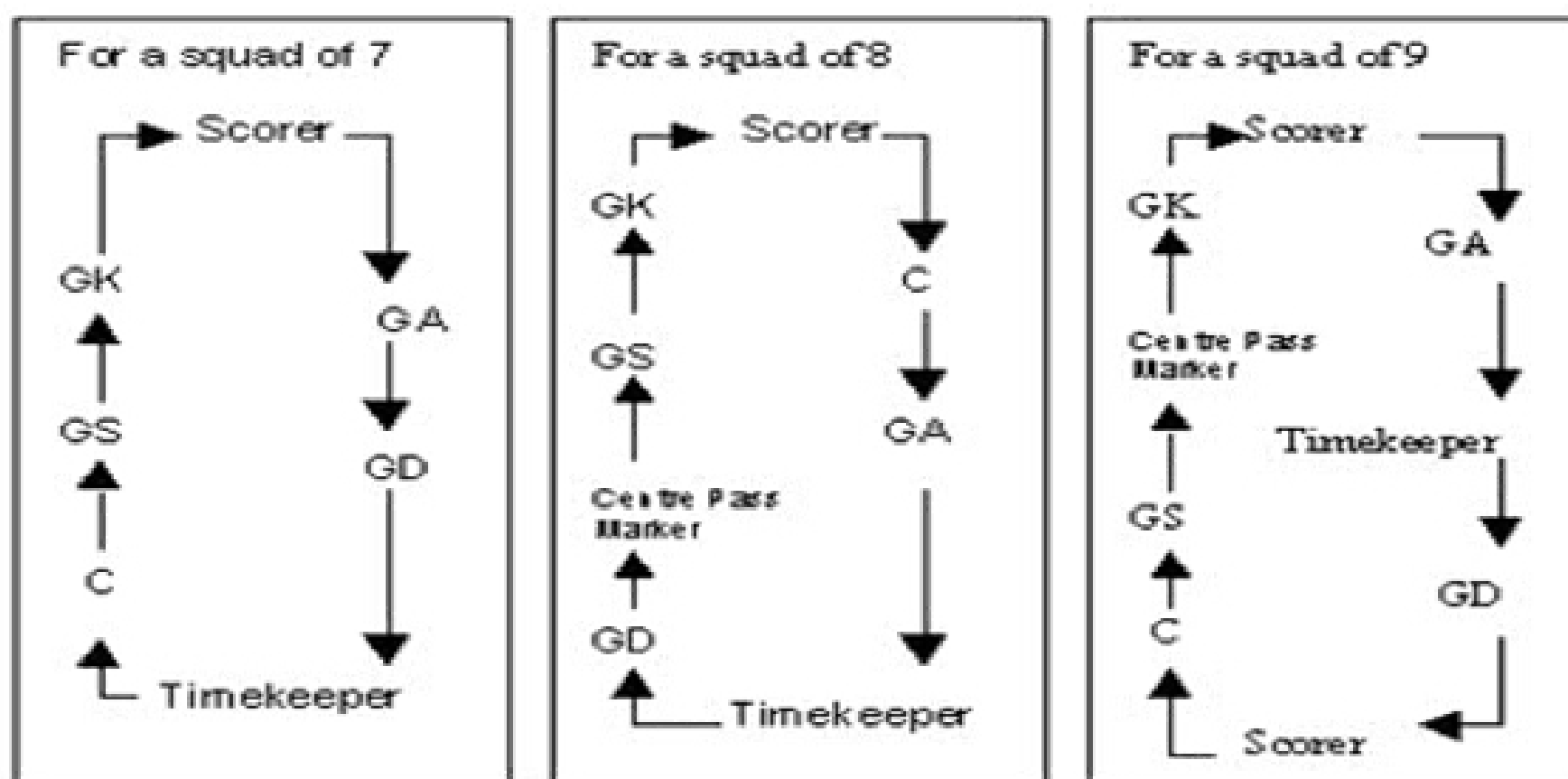

In the interest of fair play, the following rotations must be adhered to.

- Rotation pattern must allow for all players have been off court at one time throughout the rotation.
- No player should ever be off court consecutively.
- Rotation patterns will be continuous through both the matches being played and the tournament in which teams are playing.
- Injury or Illness - No time will be allowed for injury or illness. If a player has to retire, a substitution may take place in accordance with the England Netball High 5 rules.
- Substitutions - A reserve, playing because of the late arrival of a player shall continue to play in that position until half time as per the England Netball rules.



Health and Safety

First Aid is the responsibility of the staff responsible for the team.

Long hair must be tied back

No jewellery should be worn

All loose clothing must be tucked in.

No chewing gum/sweets allowed.

Please ensure your pupils bring with them any medical supplies they may need i.e. asthma inhalers.

All team teachers must ensure their pupils are under adult supervision at all times, even when performing.

Please ensure that your pupils have been thoroughly briefed with regards to health and safety



Contacts



Further Opportunities

<https://www.Englandnetball.co.uk/support/support-for-organisations/teachers/primary/>

Cathy Robinson (West): CathyRobinson@DeanTrustWigan.co.uk

<https://www.yourschoolgames.com/sgo/dean-trust-wigan/>

Sharon Walls (East): wallsS@lowtonhs.wigan.sch.uk

<https://www.yourschoolgames.com/sgo/lowtonwigan/>